



Model WHAFFS

How to install, operate and maintain your Kitchen & Bath Water Filtration System

PRODUCT REGISTRATION AND WARRANTY EXTENSION

Please register your product on whirlpoolwatersolutions.com

See warranty page for extended warranty details.



If you have any questions or concerns when installing, operating or maintaining your water filtration system, call our toll free number:

1-866-986-3223

or visit whirlpoolwatersolutions.com

When you call, please be prepared to provide the model number and date code of your product, found inside the top cover.

System tested and certified by NSF International against NSF/ANSI Standards 42, 53 and 401 for the reduction of claims specified on the performance data sheet at www.nsf.org and NSF/ANSI/CAN 372.

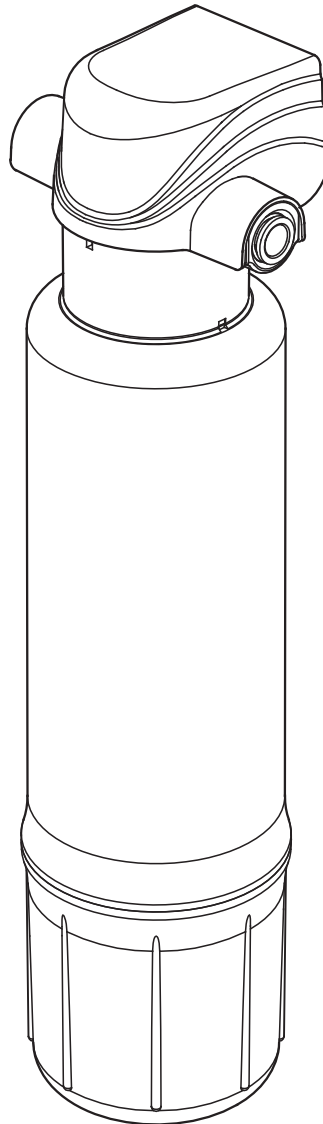

Installation and Operation Manual

Manufactured and warranted by
Water Channel Partners
1890 Woodlane Drive
Woodbury, MN 55125

201-8404384 (Rev. C 9/28/22)

TABLE OF CONTENTS

	<u>Page</u>
Before You Start	3
Specifications & Dimensions	3
Parts & Tools	4
Typical Undersink Installation	4
Installation Instructions	5-6
Step A - Install Water Supply Fittings	5
Step B - Make Tubing Connections	5-6
Step C - Turn On Water, Check for Leaks and Rinse Carbon Fines	6
Filter Cartridges	7
Filter Cartridge Life	7
Filter Cartridge Replacement	7
Troubleshooting the System	8
Exploded View & Parts List	8
Warranty	9
Performance Data	10

Before You Start

- ▼ **Read all steps and guides carefully before installing and using your kitchen & bath water filtration system.** Follow all steps exactly to correctly install. Reading this manual will also help you to get all the benefits from the filtration system.
- ▼ **Do not use with water that is microbiologically unsafe or of unknown quality without adequate disinfection before or after the system.** This system is certified for cyst reduction and may be used on disinfected waters that may contain filterable cysts.
- ▼ **All plumbing should be done in accordance with local codes and requirements.** In Massachusetts, plumbing code 248 CMR 3.00 and 10.00 shall be adhered to. Consult with your licensed plumber.
- ▼ **The kitchen & bath water filtration system works on water pressures of 30 psi (minimum) to 100 psi (maximum).** If your house water pressure is over the maximum, install a pressure reducing valve in the water supply pipe to the filtration system.
- ▼ **Do not install the filtration system outside, or in extreme hot or cold temperatures.** The temperature of the water supply to the filtration system must be between 40°F and 100°F. Do not install on hot water.

Specifications & Dimensions

Supply Water Pressure Min. - Max.	30 - 100 psi (207 - 689 kPa)
Supply Water Temperature Min. - Max.	40 - 100 °F (4 - 38 °C)
Rated Service Flow	1.85 gallons per minute (7.0 liters per minute)
Inlet - Outlet	3/8" quick connect fittings and tubing included

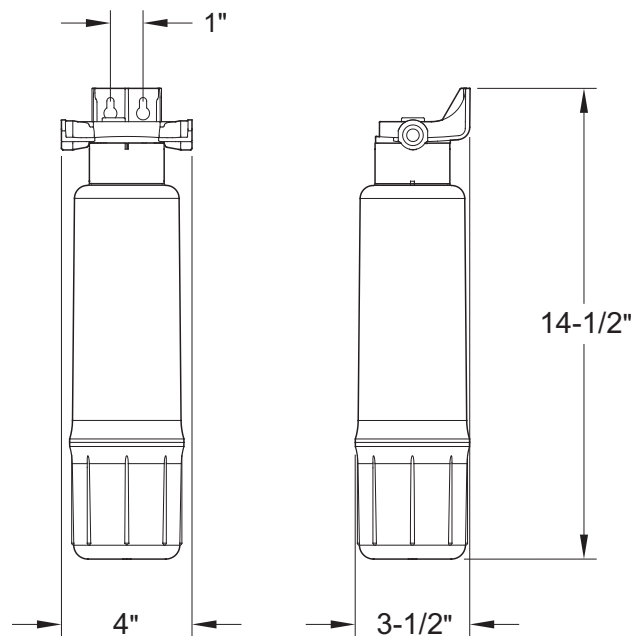

FIG. 1

Questions? Call Toll Free 1-866-986-3223 or visit whirlpoolwatersolutions.com

When you call, please be prepared to provide the model number and date code, found inside the top cover.

Parts & Tools

Included:

- Filter head / bracket
- Top cover
- Filter cartridge
- Tubing
- Bag containing installation parts and mounting screws

Not Included:

- Slotted and Phillips screwdrivers
- Pliers and adjustable jaw wrench
- Tubing cutter
- Electric drill
- Thread sealing tape

Typical Undersink Installation

Locate the water filter housing on the cold water supply pipe, under the kitchen and/or bathroom sink, to filter the cold water. Refer to the following drawing.

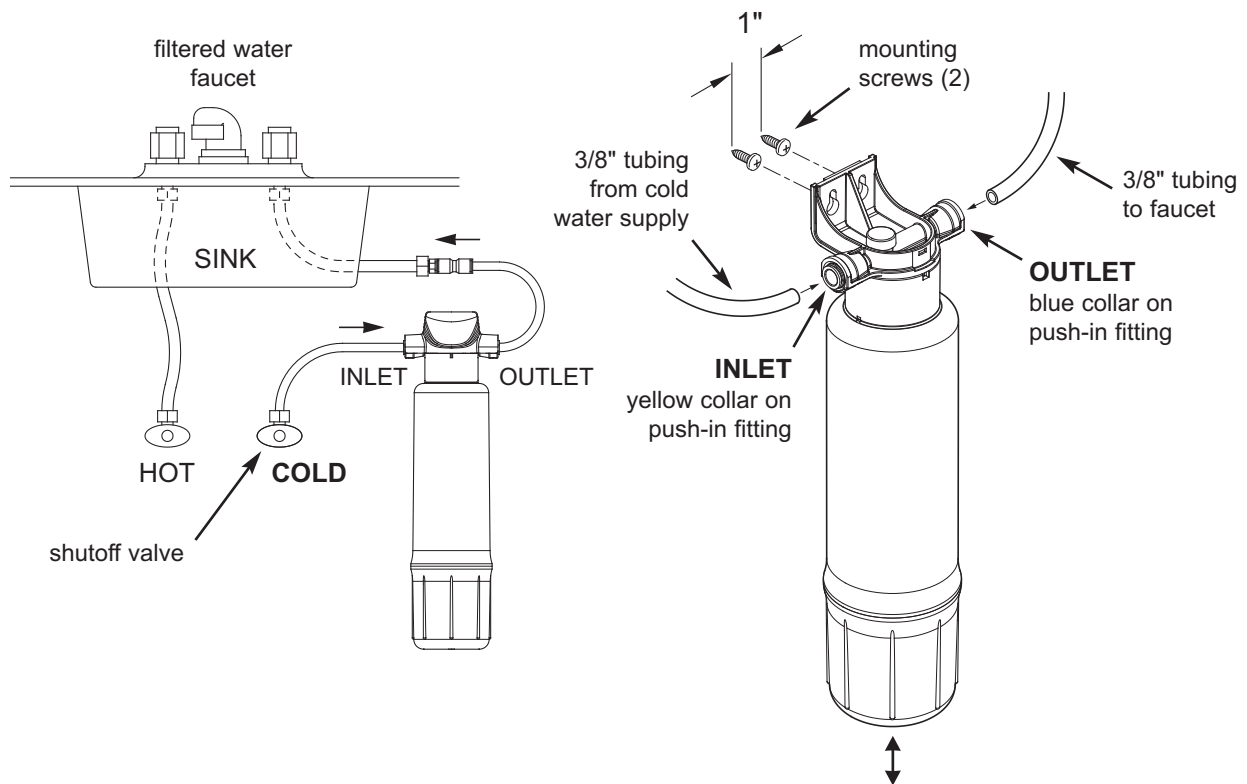

NOTE: Be sure to allow a minimum space of 1-1/2" under the system for removing the filter cartridge to change it.

FIG. 2

Installation Instructions

Step A - Install Water Supply Fittings

Check and comply with local plumbing codes as you plan, then install the fittings to connect the kitchen & bath filter into the sink's cold water supply line. Fittings (9/16-24 thread) and 3/8" O.D. tubing are included to provide connections to and from the kitchen & bath filter's inlet and outlet. A typical connection using the included water supply fittings is shown in Figure 3.

1. Close the sink's water shut off valve(s), or another shut off valve upstream from where you will install the filter, and open faucets to relieve pressure from the sink's cold water supply line.
2. Locate the line connecting the cold water shutoff to the sink faucet. Typically this line will be a flexible hose. Disconnect the nut that connects this line to the cold water shutoff. Use a bucket to catch water that drains from this line.
3. Locate one piece of the supplied 3/8" tubing, plus the supplied compression nut, ferrule and tubing insert (See Fig. 3). Assemble the parts onto the tube, as shown in Figure 3, and thread the compression nut onto the cold water shutoff. Tighten to provide a leak-tight connection.
4. Locate the water supply adaptor (supplied) and install it into the nut on the supply line which you disconnected in Step 2. Refer to Figure 3.
5. Press the stem of the water supply adaptor into one end of the supplied union connector (See Figure 3). Be sure to push the stem all the way in.

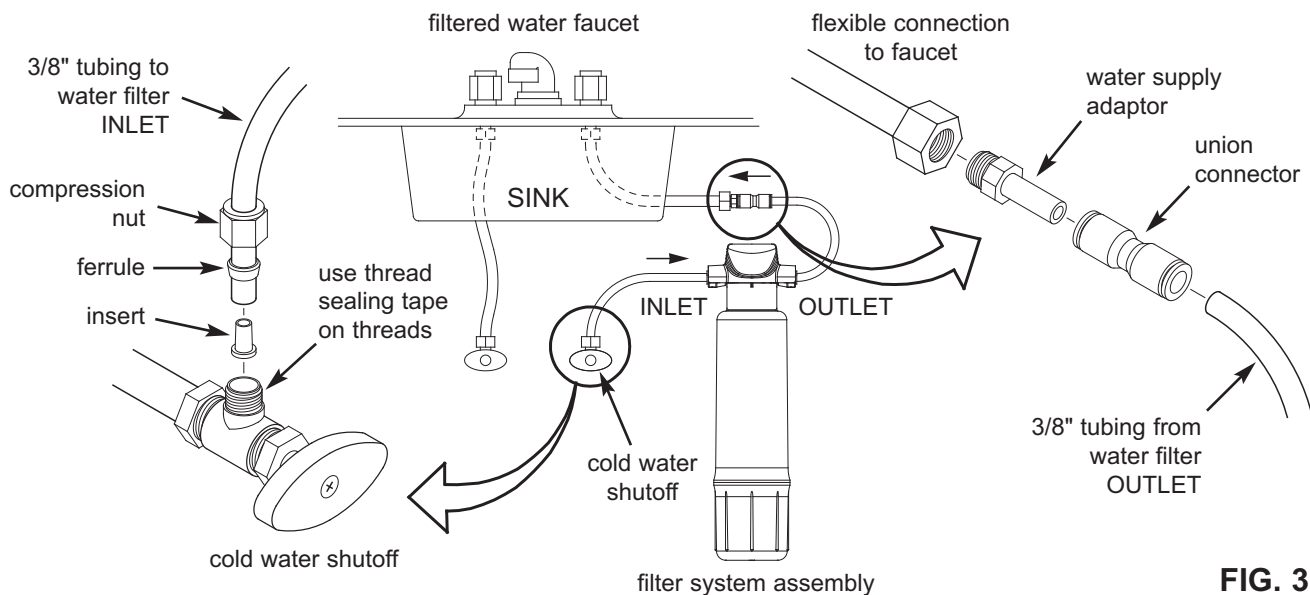

Step B - Make Tubing Connections

1. Locate the piece of supplied 3/8" tubing not used previously. Route it between the union connector and the filter system outlet (See Figures 2 & 3). Allowing some slack, measure and cut to length. Cut the ends of the tubing square.
2. Insert tubing all the way into the union connector and filter system outlet. Pull on the tubing to be sure that it's held firmly in the fittings.
3. Repeat steps 1 and 2 to connect the tube installed on the cold water shutoff to the filter system inlet.

Tubing Connection (all push-in fitting locations):

This system includes push-in fittings for quick tubing connections. When working with the fittings, do the following.

continued on the next page

Installation Instructions

continued from the previous page

Connect Tubing:

1. Use a tube cutter to cut the end of tubing square.
2. Inspect the end (about 1") of the tubing to be sure there are no nicks, scratches or other rough spots. If needed cut the tubing again.
3. Push tubing through the collet and all the way into fitting. Full engagement is 3/4" length of tube into the fitting.

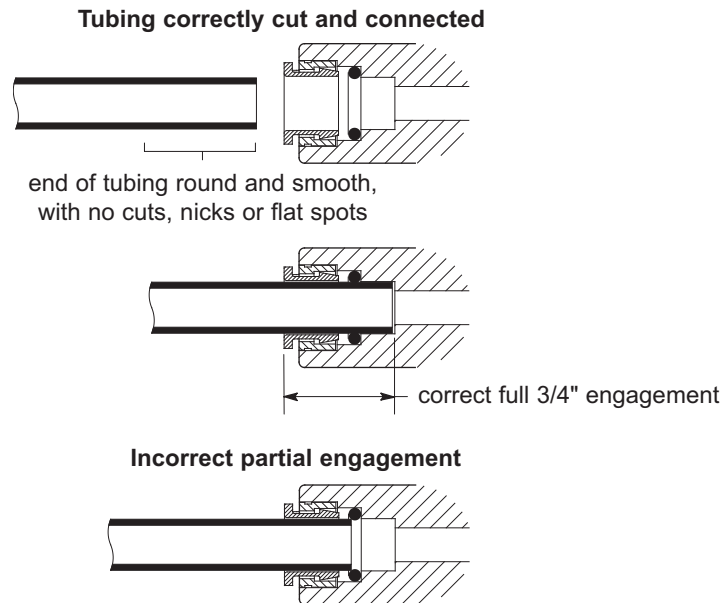

FIG. 4

To Disconnect Tubing:

1. Push the collet inward and hold with a finger while pulling the tubing out.

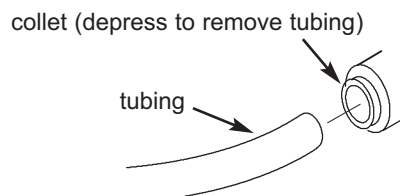

FIG. 5

Step C - Turn On Water, Check for Leaks and Rinse Carbon Fines

1. Open the shutoff valve(s) that you closed at the beginning of this installation.
2. Open the filtered water faucet to purge air from the system. When the water runs smooth, with no bubbles or spurting, close faucet and check installation for leaks.
3. Open the filtered water faucet and let water run for 20 minutes to rinse out carbon fines.

Filter Cartridges

Filter Cartridge Life

Filter Cartridges: A filter cartridge contains activated carbon. When new, open the filtered water faucet and allow fine, carbon particles to purge from the cartridge. Flush for 20 minutes. It is recommended to replace filter cartridge every six months of use. There are several variables that determine how long a cartridge will last. These include:

1. How much water you use, and
2. How much sediment, taste and/or odor, or other unwanted substance, is in the water.

Use the following information as a guide. However, no matter which type of cartridge you are using, you will know it is time to replace them when you first notice the return of the unwanted sediment, taste and/or odor in your water, or when the flow diminishes or stops.

Whirlpool® Kitchen & Bath Water Filtration System model WHAFFS with replacement element WHAFFF conforms to NSF/ANSI 42, 53 and 401 for the specific performance claims as verified and substantiated by test data. The rated capacity for this system is 2000 gallons (7570 liters) at a rated service flow of 1.85 gallons per minute (7.0 liters per minute).

**Register for reminders to change filters
at whirlpoolwatersolutions.com**

Filter Cartridge Replacement

NOTE: There is no need to shut off the water supply when replacing the filter cartridge.

1. Turn the filter cartridge to the left to remove cartridge from the filter head.
2. Dispose of the cartridge in a proper manner.
3. Install new cartridge. Turn the cartridge to the right to re-attach to the filter head.

Filter Cartridges: Filter cartridges contain activated carbon, a black powder. When new, open the filtered water faucet and allow fine, carbon particles to purge from the cartridge. Flush for 20 minutes.

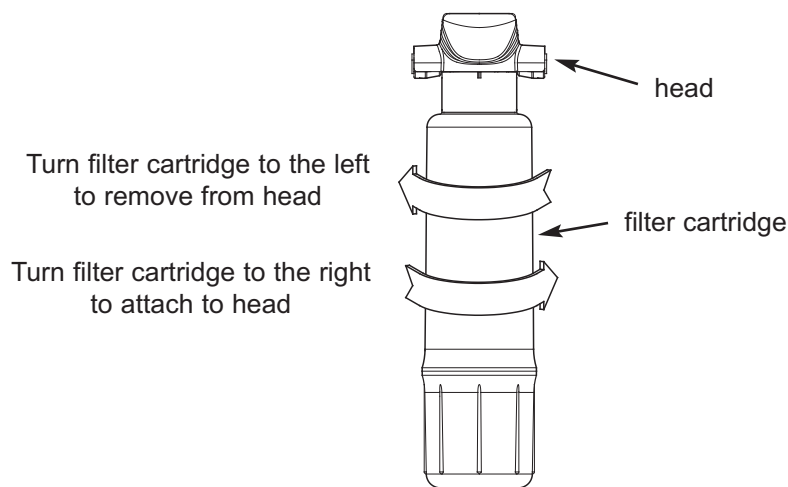

FIG. 6

Questions? Call Toll Free 1-866-986-3223 or visit whirlpoolwatersolutions.com

When you call, please be prepared to provide the model number and date code, found inside the top cover.

Troubleshooting the System

Problem: Taste and/or Odor.	
Cause: Filter cartridge exhausted.	Correction: Replace filter cartridge.
Cause: System contaminated.	Correction: Sanitize system. Call 1-866-986-3223 for instructions.
Problem: Water leaks at push connect fittings.	
Cause: Tubing not pushed in all the way.	Correction: Push tubing in all the way into fittings.
Cause: Tubing not cut square.	Correction: Cut tubing square.
Cause: Tubing nicked.	Correction: Remove nicked portion, reinsert tubing into fitting.
Cause: Outer tubing surface not smooth.	Correction: Remove rough portion, reinsert tubing into fitting.

Parts List

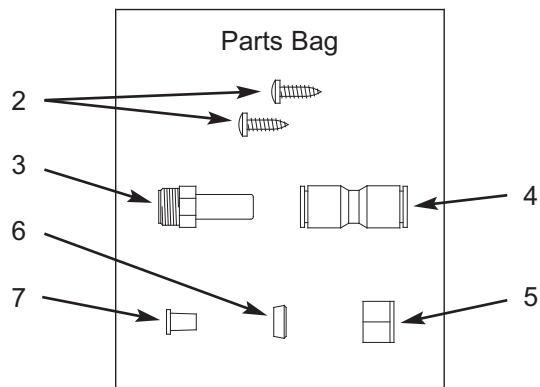
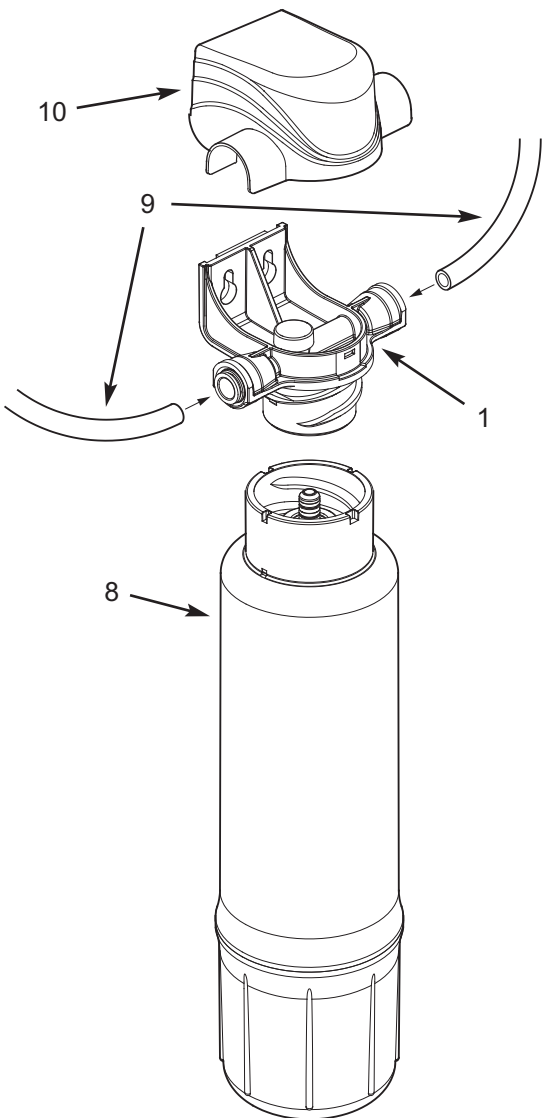

Key No.	Part No.	Description
1	1042-45-HA	Head Assembly with Quick Connect Fittings
-	1042-45-AC	Parts Bag (includes Key Nos. 2-7)
2	↑	Mounting Screws (2)
3	↑	Water Supply Adaptor
4	↑	Union Connector, 3/8" to 3/8"
5	↑	Compression Nut, 3/8"
6	↑	Ferrule, Plastic, 3/8"
7	↑	Tubing Insert, 3/8"
8	WHAFFF	Repl. Filter Cartridge, Taste & Odor *
9	7168435	Tubing, 3/8" OD x 72" long, White
10	1128-13-01	Top Cover
■	1128-13-AA	Owner's Manual

* Please purchase replacement cartridges from the retailer where you bought your water filtration system.

■ Not illustrated.

Manufactured and warranted by
Water Channel Partners
1890 Woodlane Drive
Woodbury, MN 55125

To order repair parts call toll free 1-866-986-3223.

EXTEND YOUR WARRANTY:

You can turn your water filtration system's one year factory warranty into a lifetime warranty by saving your receipts for purchases of Whirlpool® replacement filter cartridges. See "Lifetime Warranty" below for details.

WARRANTY

KITCHEN & BATH WATER FILTRATION SYSTEM - MODEL WHAFFS (not including filter cartridges)

Warrantor: Water Channel Partners, 1890 Woodlane Drive, Woodbury, MN 55125

One Year Warranty:

Warrantor guarantees, to the original owner, that the Kitchen & Bath Water Filtration System (WHAFFS), when installed and maintained in accordance with the instructions, will be free from defects in materials and workmanship for a period of one (1) year from the date of purchase.

Lifetime Warranty:

Warrantor guarantees, to the original owner only, that the Kitchen & Bath Water Filtration System (WHAFFS) will be free from defects in materials and workmanship for the lifetime of the owner, provided that:

- The system is installed and maintained in accordance with the instructions in the same home where it was originally installed.
- The owner replaces the filter every six (6) months and saves their receipts, for proof of purchase of the Whirlpool WHAFFF filter cartridge, in case a warranty claim is made. Purchase of no more than two (2) WHAFFF filter cartridges in a 12 month period may be applied toward compliance with this warranty.

Failure to adhere to the above requirements from the date of purchase voids the lifetime warranty.

If, during such respective periods, a part proves, after inspection, to be defective, Warrantor will, at its sole option, either replace or repair the part without charge except normal shipping and installation charges. Labor to maintain the equipment is not part of the warranty. Filters, which are expendable, are not covered by the warranty.

TO OBTAIN WARRANTY PARTS, SIMPLY CALL 1-866-986-3223 for assistance. This warranty applies only while this product is in use in the United States or Canada.

General Provisions

The above warranties are effective provided the Kitchen & Bath Water Filtration System is operated at water pressures not exceeding 100 psi, and at water temperatures not exceeding 100°F; provided further that the Kitchen & Bath Water Filtration System is not subject to abuse, misuse, alteration, neglect, freezing, accident or negligence; and provided further that the Kitchen & Bath Water Filtration System is not damaged as the result of any unusual force of nature such as, but not limited to, flood, hurricane, tornado or earthquake.

Warrantor is excused if failure to perform its warranty obligations is the result of strikes, government regulation, materials shortages, or other circumstances beyond its control.

***THERE ARE NO WARRANTIES ON THE KITCHEN & BATH WATER FILTRATION SYSTEM BEYOND THOSE SPECIFICALLY DESCRIBED ABOVE. ALL IMPLIED WARRANTIES, INCLUDING ANY IMPLIED WARRANTY OF MERCHANTABILITY OR OF FITNESS FOR A PARTICULAR PURPOSE, ARE DISCLAIMED TO THE EXTENT THEY MIGHT EXTEND BEYOND THE ABOVE PERIODS. THE SOLE OBLIGATION OF WARRANTOR UNDER THESE WARRANTIES IS TO REPLACE OR REPAIR THE COMPONENT OR PART WHICH PROVES TO BE DEFECTIVE WITHIN THE SPECIFIED TIME PERIOD, AND WARRANTOR IS NOT LIABLE FOR CONSEQUENTIAL OR INCIDENTAL DAMAGES. NO WARRANTOR DEALER, AGENT, REPRESENTATIVE, OR OTHER PERSON IS AUTHORIZED TO EXTEND OR EXPAND THE WARRANTIES EXPRESSLY DESCRIBED ABOVE.**

Some states do not allow limitations on how long an implied warranty lasts or exclusions or limitations of incidental or consequential damage, so the limitations and exclusions in this warranty may not apply to you. This warranty gives you specific legal rights, and you may have other rights which vary from state to state. This warranty applies to consumer-owned installations only.

© / ™ ©2022 Whirlpool. All rights reserved.

Manufactured under license by Water Channel Partners, Woodbury, Minnesota.

Warranty provided by manufacturer.

Performance Data

Model WHAFFS Kitchen & Bath Water Filtration System

IMPORTANT NOTICE: Read this performance data and compare the capabilities of this unit with your actual water treatment needs. It is recommended that, before purchasing a water treatment unit, you have your water supply tested to determine your actual water treatment needs. This filter system is designed to be used for the reduction of the performance claims listed below. Do not use where water is microbiologically unsafe or of unknown quality, without adequate disinfection before or after the system. Systems certified for cyst reduction may be used on disinfected water that may contain filterable cysts. While testing was performed under standard laboratory conditions, actual performance of this system may vary based on local water conditions. Some or all of the contaminants reduced by this unit may not be in your water supply. See elsewhere in this owner's manual for further instructions on filter cartridge replacement, system installation, operating procedures, and warranty. The maintenance instructions must be followed for the product to perform as indicated below.

PERFORMANCE CLAIMS		
Substance	NSF Required Influent Challenge Level (mg/L) ¹	NSF Max. Permissible Product Water Concentration (mg/L) ¹
Benzene	0.015 ±10%	0.005
Chlorine Taste & Odor	2.0 ±10%	1.0
Cyst	≥50,000 #/mL ²	99.95% ³
Lead @ pH 6.5	0.15 ±10%	0.010
Lead @ pH 8.5	0.15 ±10%	0.010
Mercury @ pH 6.5	0.006 ±10%	0.002
Mercury @ pH 8.5	0.006 ±10%	0.002
Particulate, Class I (0.5 to <1 micron)	10,000 #/mL ²	85% ³
Microplastics (0.5 to <1 micron)	10,000 #/mL ²	85% ³

¹ Milligrams per liter, which is equivalent to parts per million (PPM).

² Particles per milliliter.

³ NSF minimum percent reduction requirement. The acceptance level for this substance is based on percent reduction, rather than maximum effluent concentration.

General Information

This system has been tested according to NSF/ANSI 42, 53 and 401 for reduction of substances listed above. The concentration of the indicated substances in water entering the system was reduced to a concentration less than or equal to the permissible limit for water leaving the system, as specified in NSF/ANSI 42, 53 and 401. The testing was performed using spiked tap water at a flow rate of 1.85 gallons per minute (7.0 L/min.), pH of 7.5 ± 0.5, pressure of 60 psig, and temperature of 68 ± 5°F.

This product is protected by U.S. patent no's: 6,866,704; 6872.311; 7,276,166; 7,296,691; 7,241,388; 7,287,650; 7,566,014; 8,056,733; applicable U.S. patent applications; foreign patents and foreign patent applications.

Installation Requirements

Pressure Range30-100 psig (207-689 kPa)
 Temperature Range40-100°F (5-38°C)
 Service Flow Rate1.85 GPM (7.0 LPM)
 Service Life.....2000 gallons (7570 Liters)

Maintenance

Filter cartridges should be replaced every 2000 gallons or six months, whichever comes first. For replacement elements, call 1-800-986-3223 or visit www.whirlpoolwatersolutions.com. Replacement filter prices will vary. Estimated cost of replacement filter cartridge WHAFFS ranges from \$70 to \$100.

System tested and certified by NSF International against NSF/ANSI Standards 42, 53 and 401 for the reduction of claims specified on the performance data sheet at www.nsf.org and NSF/ANSI/CAN 372.





FOR IOWA USE ONLY

All sales in Iowa require the following signature before consummation of sale. These signatures must be retained by seller/renter for 2 years minimum.

Buyer/Renter _____ Date _____

Seller _____ Date _____

Seller's Address _____

Seller's Phone No. _____

Product: Whirlpool Model WHAFFS Kitchen & Bath Water Filtration System